



Digital Overcurrent-Time and Overload Protection

DSZ 2

(Version 6)

1 Application

This multifunction protection device is mainly used as a non-directional overcurrent-time protection. An overload protection module extends the application range. It can be applied in every system type as line protection and, together with other protection devices, also as equipment protection (for example transformer, motor, generator). In feeders with high inrush currents (e.g. unloaded transformer) it can be used because of its inrush restraint function or switch-on protection. Tripping of intermittent earth-faults is possible, as well as a preferential phase treatment in case of double earth-faults is possible.

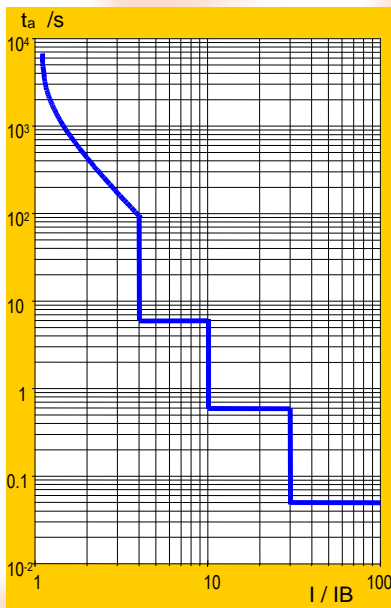

Fig. 1: A possible characteristic

A special design with sensitive earth current measuring connected through a cable-type current transformer can be used for tripping of earth faults.

The installed CT's can be connected to rated currents of 1 A and 5 A. For universal application wide range power supplies are used.

2 Main characteristics

- Due to its compact design, it can also be mounted into low-depth switch-gear cells.
- Selection of rated current (1 or 5 A) is easy by terminal connection.
- A short start-up time of the protection device ensures quickest availability after auxiliary voltage was not applied.
- Readout and setting is menu driven so the use of the PC operator software is not forced.
- Identical philosophy of both operating with the device and with PC operating program ensures to find one's way quick.
- The use of binary "functional switches" for setting the device enables a simple selection between functional alternatives. The winning advantage of this adjustment method is the automatic suppression of all settings, which are not necessary. This decreases the size of adjustment.
- All inputs and outputs can be freely assigned in a matrix with rows containing software-functions and columns representing physical I/O's.
- Logic combination for optocoupler inputs is possible.
- The setting sets are stored in an EEPROM to be preserved if the supply voltage and the back-up battery fail.
- For instant enlightenment of both system and protection device status one can use LED indications, meas-

urement display and short reports on LCD.

- In addition to the event logging a disturbance recorder is integrated which ensures diagnostic and documentation of operation and fault events.
- Comprehensive treatment of both line to line and line to earth-faults.
- Two switchable characteristic sets allow adaptation to changed conditions instantly.
- Measures to increase the reliability and availability include - among other things - a comprehensive program of self-diagnostic functions as well as callable tests.
- Sensitive earth current measuring is optional available (≥ 10 mA).
- Two pulse shaper stages for extended signal processing of inputs.

New or improved in this version:

- More sensitive earth current measurement in standard model
- Current annunciation stages
- Switch-on protection
- Inrush restraint ($I_{100\text{Hz}}/I_{50\text{Hz}}$)
- Intermittent earth-fault detection
- Circuit breaker failure protection
- Blockade signal treatment

3 Construction

The DSZ 2 is housed in a sheet-steel enclosure in the following designs:

- panel surface-mounting
- panel flush mounting.

Additionally three different installation positions exist – current terminals

- at the bottom
- right or
- left hand side

For all versions, the low depth of 140 mm allows the installation into medium-voltage switchgear cells. Therefore, be-

hind the DSZ 2 other devices like terminals may be located.

For panel surface mounting, the terminals can be accessed from the front panel, whereas for panel flush-mounted units they can be accessed from the rear side.

The front operator panels of all versions are equal. They include the membrane keyboard, a four-line LCD display of 20 characters per line, 12 LED's and a 9-pin Sub-D connector for plugging in a PC.

The optional IEC 60870-5-103 interface is available in two physical designs: optical fibre connection or RS485 twisted-pair wire. The optical fibre interface has a connector for the transmission and reception direction. It is located in the upper level of the terminals. The alternative RS485 wire interface uses terminals.

4 Protective functions

4.1 Treatment of line-faults

Short circuit can be solved by the three-stage definite-time overcurrent protection ($I_L >$, $I_L >>$ und $I_L >>>$). Current measurement is phase-selective in each phase.

Alternatively the overcurrent-time stage $I_L >$ can be used as an inverse-time overcurrent protection. The tripping time is determined using the formulas indicated below (IEC 60255-3 or BS 142).

1. long time inverse:

$$t_{a \max} \geq t_a = \frac{120}{\left(\frac{I}{I >}\right) - 1} \cdot t >$$

2. inverse:

$$t_{a \max} \geq t_a = \frac{0,14}{\left(\frac{I}{I >}\right)^{0,02} - 1} \cdot t >$$

3. very inverse:

$$t_{a \max} \geq t_a = \frac{13,5}{\left(\frac{I}{I >}\right) - 1} \cdot t >$$

4. extremely inverse:

$$t_{a \max} \geq t_a = \frac{80}{\left(\frac{I}{I >}\right)^2 - 1} \cdot t >$$

Wherein are:

$t_{a \max}$: maximum tripping time (setting value)

t_a : tripping time

$t >$: time factor

I : measured current

$I >$: current setting value

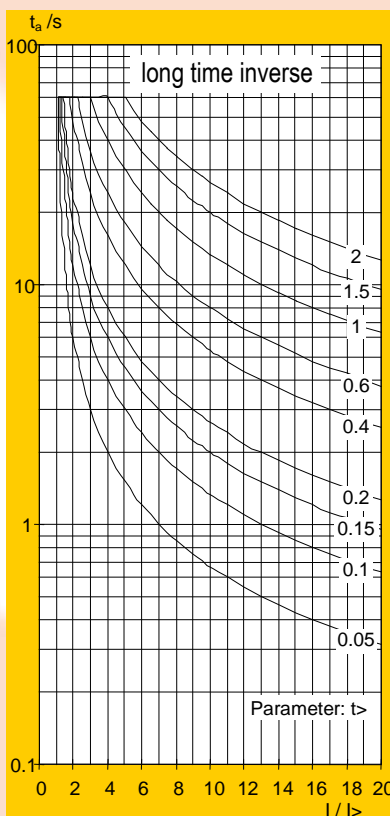

Fig. 2: Characteristics for "long time inverse"

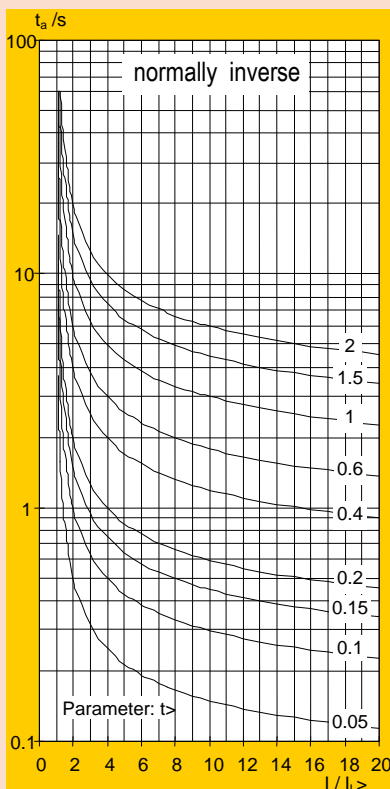

Fig. 3: "inverse"

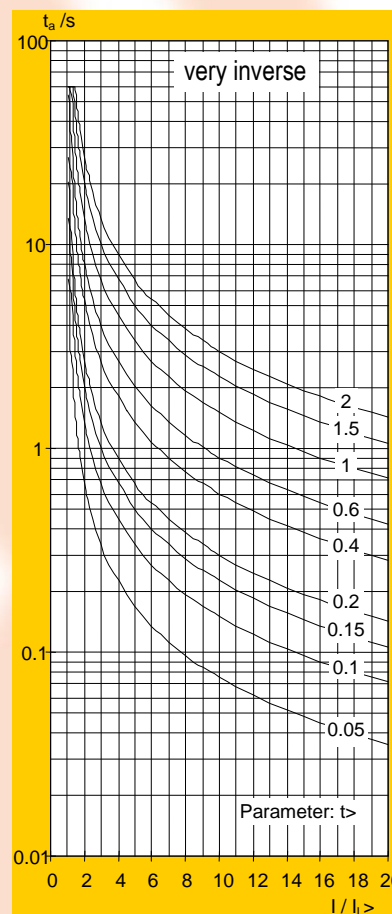

Fig. 4: "very inverse"

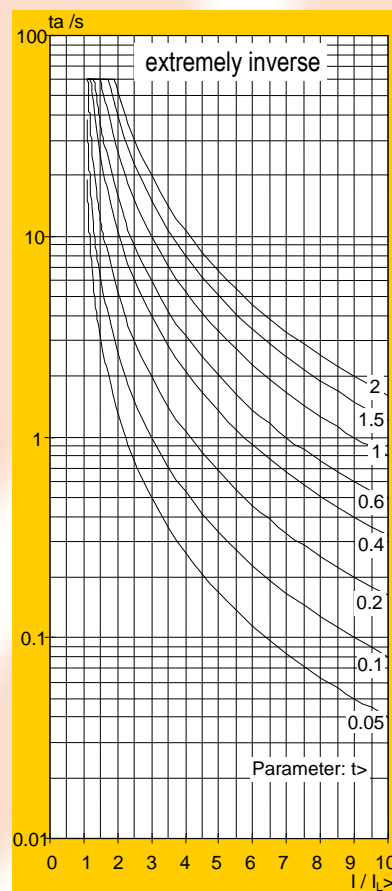

Fig. 5: "extremely inverse"



4.2 Treatment of single pole line to earth-faults

This protection function is used mainly in systems having insulated or compensated star points. It serves the treatment of double earth-faults. In this case often the strategy of switching off only one earth-fault root. The rest of the system can have an earth-fault for a longer time. To switch off one root a preferential phase treatment is integrated.

4.3 Treatment of earth-faults

DSZ 2 measures earth current (using a CT) beside line currents. Three setting stages ($I_{E>}$, $I_{E>>}$, $I_{E>>>}$) are available. The consequence of a transgression can be chosen. A report of the setting value transgression can be signalled also in cases at which a trip isn't intended due to an earth current.

To avoid spurious starts of the earth-fault current-time protector $I_{E>}$, for example due to transformer faults if no cable-type CT is used, the operate value is stabilised. Stabilising the earth-fault current serves to rise the operate value of the earth-fault current-time protector depending on the amount of the phase currents which are higher than its setting value. This improved stabilization is most strongly effective for three-pole short circuits.

For the $I_{E>}$ - stage users of the DSZ 2 may choose between definite-time overcurrent protection not depending on the current amount and inverse-time overcurrent protection depending on the current amount. The same characteristics mentioned in chapter 4.1 are available.

In the new version earth current measurement has a double sensitivity to allow settings from 0.5·In on. With a factor of 5 more sensitive earth current transformer is available as an option in addition. To detect single-phase-to-earth faults it should be connected through a cable-type CT. Very small earth-fault currents beginning from 0.1·In are valued.

4.4 Treatment of intermittent earth faults

Very short earth faults cannot always be recognized by the "standard" $I_{E>}$ - stage because the timer stops and resets after each end of a short fault. If such short-time earth faults appear repeatedly behind each other, tripping can be meaningful for the feeder.

A special protection function makes the capturing and switching off of intermittent earth faults possible.

4.5 Current annunciation stages

Two warning stages for phase currents and one for the earth current that signals an exceeding of its operate value after a adjustable time delay support the management.

4.6 Switch-on protection

The switch-on protection has its own current operate values: This allows detecting short circuits from high inrush currents (not detectable by harmonics). When switching on to an existing short circuit, this function can produce an undelayed TRIP command. Startings caused by inrush currents can be blocked.

The input-signal "CB manual close" starts the operate time of this function. Short circuits detected during this time are switched off immediately. A possibly switched on auto-reclosing function will be blocked.

4.7 Inrush restraint (IR)

Spurious tripping by magnetising inrush is avoided by valuating the adjustable ratio from the 2nd to the 1st harmonic in the measured currents. Cross blocking is possible.

With higher currents no blocking is issued (limit adjustable).

4.8 Thermal overload protection

The integrated overload protection works with a thermal model.

The calculated thermal level will be compared with the set tripping value (when tripping is selected) respectively warning level value. If occasion arises, a response or an alarm is issued.

The influence of the previous load will be regarded. The characteristic meets IEC 60255-8.

$$t_a = \tau \cdot \ln \left[\frac{\left(\frac{I}{I_B} \right)^2 - \left(\frac{I_P}{I_B} \right)^2}{\left(\frac{I}{I_B} \right)^2 - k^2} \right]$$

Wherein are:

- t_a tripping time after overload has been started
- τ heating time constant of the equipment
- I actually flowing current
- I_B basic current
- I_P preloading current
- k factor for multiplying the basic current to reach the operating limit.

A reclosing lockout prevents the switching on of the protective object as long as the thermal level is higher than a set value.

4.9 Circuit-breaker failure protection

The circuit breaker failure protection CBF is used for control of correct execution of the TRIP command by the circuit breaker. It supervises an assigned TRIP command of the DSZ 2 and / or of another equipment located at the same circuit breaker.

Additionally a TRIP command can be executed coming from subordinate outgoing feeders because of a circuit breaker failure.

Both last mentioned tasks require the use of an input for the TRIP command. After a TRIP command the current has to fall below a special setting value within adjustable times.

4.10 Reverse interlock

Using an optocoupler input, the DSZ 2 may be controlled so that it functions as a rapid busbar protection. Protector response must be within a higher grading time than that of the outgoing feeder protectors, if a fault occurs on an outgoing feeder. On the other hand, the protector must trip within a shortest possible time if a fault occurs in busbar area. If during a starting within the action time started simultaneously no response (start) signal is supplied from a protector in the outgoing feeders the TRIP command is issued. A response signal from an outgoing feeder protector to the input of the DSZ 2 causes tripping in grading time.

The connection between devices may be monitored for disturbances.

4.11 Auto-reclosing (AR) (Option)

The DSZ 2 is equipped with a three-phase auto recloser. Up to five reclosures are possible with the first interruption being adjustable as a short-time interruption. As any other function, the auto-recloser may be switched off if unused (also using two optocoupler inputs and through the substation control interface). It may also be blocked temporarily by an input signal. Other input signals required for the auto-recloser are the ready signal from the circuit breaker and the manual close signal.

The auto-recloser may be started by an external signal through an input.

Various starting conditions for the auto-recloser may be set in the protector.



When looped through a break contact of the DSZ 2, the "breaker tripped" signal may be interrupted in case the trip command is not final.

4.12 Input signal processing

The input signals wanted for the different protective and additional functions are freely programmable; several inputs for one function may be used.

Processing the optocoupler input signals, the logic functions negation (NOT), AND, OR are available. As a result, there are logical input signals for internal processing in the protector.

4.13 Pulse shaper stage

The pulse shaper stages offer the possibility of changing up to two input signals in their time characteristic. So, delays, extensions, shortenings, displacements and storage may be realised. The signal can depend on internal status of the protection relay also. These result signals may be routed to an output signal (input / output coupling).

The pulse shaper stage has two ports functioning independently of each other.



Fig. 6: Example for one effect of the pulse shaper stage

4.14 Change of characteristic sets

Two characteristic sets may be entered. The respectively active set can be selected by an operator action or by command from the substation control system. Changing the configuration allows to switch between the characteristic sets using the optocouplers.

5 Additional functions

5.1 Display of operating values

As long as no trip, alarm or malfunction messages are present, the DSZ 2 display indicates the phase currents and the earth current selectable as

- primary or
- secondary values (referred to rated currents).

Alternating the average r.m.s. and their peak values (dragging indicator) are shown. When overload protection is

enabled, its actual thermal level and the maximum are shown.

5.2 Visual display of system faults

For first short information concerning a system fault or device status, 12 light emitting diodes (LED's) and a four-line display with 20 characters each per line are available.

The LED display as delivered in the standard configuration is shown in Table 1. All LED's can be freely assigned. Except for the upper two, the LED's are yellow. The LED "G" is green while the LED "R" is red. Furthermore, they have three possible states:

- off
- steadily on
- flashing

This provides a large variety of optical signals. As an output command can be derived practically from each sub-function of the DSZ 2, the LED assignment can be changed within wide limits by changing the configuration.

LED	steady light	flashing light
green G	Protection available	u
red R	Alarm	l Malfunction t
yellow 0	TRIP	t
yellow 1	I1>	I1>>(>)
yellow 2	I2>	I2>>(>)
yellow 3	I3>	I3>>(>)
yellow 4	IE>	IE>>(>)
yellow 5	–	–
yellow 6	–	–
yellow 7	–	–
yellow 8	–	–
yellow 9	–	–

Table 1: LED assignment on delivery for DSZ 2 (abbreviations are as follows: u: updating l: latching t: additional indication on LCD)

In case of an alarm, a DSZ 2 malfunction or a trip a short report will be displayed. The four-line LCD text display shown after a "final TRIP" command includes the following information:

- tripping reason,
- period of fault (operating time until TRIP command),

- r.m.s. value of current in the individual phases and earth at the time of the TRIP command output, It should be considered that this LCD report is only used as first information after a starting or a "final TRIP". Information that is more detailed can be found in the event and disturbance data memories of all relays started.

5.3 Event logging

Event logging is used to make a follow-up analysis of what happened in the protective object and in the protective relays.

To achieve a better survey, the events are divided into the following groups:

- system faults,
- indications,
- operator actions and
- internal malfunctions and alarms.

Moreover, it can be seen whether the events occurred during

- normal, or
- test operation.

The division into

- main and
- subevents

supports the temporal classification. Main events are numbered and time-stamped. Subevents contain the time in ms relative to the assigned main event. The event memory is a shift memory whose oldest events are overwritten.

The content of the event memory can be selected and displayed on the front panel without using a PC.

The installed back-up battery preserves the event memory content even if the supply voltage fails.

5.4 Disturbance data logging

Disturbance data logging means the storage of the digitised instantaneous values of measured input quantities together with the time marks of some important events (like start trip and optocoupler inputs). Logging clock is 1 ms. Logging is activated by:

- system faults located by the protector or
- external logging signals

For logging the power system failures, there are two possibilities:

1. Continuous logging from "coming" to "going" of the general start with a 50 ms pre-travel, where the maximum logging duration for a fault is 4 s,
2. event controlled logging with 50 ms pre-travel and 150 ms overtravel.



The controlling events are:

- starting comes,
- starting goes,
- starting changes,
- TRIP-command

Several logs with a total of ca. 19 s are possible. The disturbance data logging caused by an input signal is always continuous during the active signal, max. 4 s.

The stored disturbance data can only be visualised on a PC screen using PC operating programs.

When the RAM's back-up battery is intact, the content of the event memory is preserved even if the supply voltage fails.

5.5 Measured-value checking

Measured current values arriving through current transformers are monitored for plausibility during the non-started state of the DSZ 2 when selected.

5.6 Time synchronisation

Beside the default time synchronisation by a substation control system, it is possible to set the time 12:00:00 by an optocoupler input signal.

6 Tests

6.1 Self-test

Comprehensive monitoring routines of the hardware and for the software are provided to detect and signal malfunctions of the protector. There are cyclic tests and tests during start-up.

Depending on the detected abnormal condition, the protector is taken out of operation or an alarm is issued. Using the green LED to indicate the ready state and the red LED for malfunction and alarm signal is advisable. The pre-configured signal relay "Protection available" signals any malfunction and lack of auxiliary voltage. Alarms may be configured to another signal relay.

6.2 C.B.-Test, Test auto-reclosing

To test the break and make circuits of the circuit breaker, an auto-reclosing test operation may be performed. Pressing the „Tests“ key on the DSZ 2 activates this function. If an auto-reclosure is impossible, this function may work as a trip test.

6.3 Checking Optocoupler Inputs

Optocoupler-inputs may be monitored by the test-function "Optocoupler test".

6.4 Test of fibre optic interface

An easy to use check for transmitter, receiver and fibre optic cable is integrated.

6.5 Application of test plug devices

Checking the mounted protection relays periodically many power supply companies apply test plug devices or test selector switches that cause a safe switch over from the measured quantities of the system to the test devices. The TRIP command to the circuit breaker is also involved into the switch over. Building the "check/test mode", the test plug device respectively the test selector switch has to make a binary signal for one optocoupler input of the protector available. This marks all logged events as "test". Information blocking is available to substation control equipment by an optocoupler input too.

7 Serial interfaces

The front 9-pole Sub-D connector constitutes the interface S0 for the operator PC.

The IEC 60870-5-103 interface S1 for connection to the substation control system is available as an option. The optical fibre variant is a point-to-point connection while the RS485 is a twisted-pair half-duplex connection (several devices may be connected).

8 Operation

8.1 Front panel

The following operations can be executed on the front panel:

- Reading and resetting of LED's and display provided automatically by the relay including the following:
 - operating value display during normal operation,
 - LCD report after a TRIP command of the protector,
 - LCD report after switching off the protector and because of an internal malfunction.
 - In case of an alarm, the operating values and the alarms are displayed.
- Setting of the protector
Pressing the password-protected "Setting" key displays an easily comprehensible plain-text menu comprising the following main items:
 - *Equipment adaptation* - data concerning the installation and the system,

– *Protective functions* – switching the protective and additional functions on or off,

– *Input configuration* - free assignment and logic combination of optocoupler input signals to device software functions.

– *Output configuration of relays and LED's* - free assignment of the possible output commands to trip relays, signal relays and LED's, this can generate group signals,

– *Characteristic sets* - setting values for the selected protective functions are separately adjustable for two characteristic sets,

– *Device address*,

– *Operator control* - common settings, e.g. protector On/Off, password, date and time, operating mode, etc.

- Display of stored information

After pressing the "Readout" key the stored information may be indicated on the display:

- logged events (with elapse time),
- all settings,
- information on the protector type, e.g. versions.

As the key is not password-protected and the information selection is shown in a plain-text menu, it is easy to get a local readout.

- Calling of tests

Pressing the "Tests" key accesses a menu used for the above-mentioned tests and the manufacturer's service. The menu is password-protected.

8.2 PC operator routine COMM-3

Although no PC software is necessary for setting and readout of the protection device PC operator routine COMM-3 and graphic software SDA 2 is available. It is used for preparing and performing the setting of the digital protection relay at the engineer's place of work. In addition to setting the protectors, the routine may also be used for reading out and displaying events and with the additionally graphics software SDA disturbance data can be displayed. Archiving of settings and events is easy to do.

COMM-3 consists of a management program and several device programs (characterised by the "structure" number).

Graphic display and evaluation of disturbance data are by the graphics software featuring the COMTRADE file



format (IEEE standard C37.1991). Using this file format data exchange may be performed between compatible devices such as state of the art test devices.

8.3 Control by substation

The IEC 60870-5-103 interface of digital protectors to the substation control equipment is optionally available. Regardless of the manufacturer, this interface supports the connection of protectors to correspondingly compatible equipment.

The scope of signals and commands agreed upon by the compatibility class 2 of an overcurrent-time protection is available. Additional private signals give a complete outline of what happens in the protection device.

9 Specifications

The protection relay satisfies the requirements of the product standards EN 60255-6 (IEC 255-6); DIN 57435, part 303; IEC 255-3.

Mechanical construction

- sheet-steel housing for
 - panel surface mounting
 - or panel flush mounting
- dimensions see dimensioned drawings
- weight approx. 5.5 kg
- degree of protection: housing IP 51
- terminals IP 20
- terminals
 - transformers solid wire 0.5 ... 16 mm²
 - stranded wire 0.5 ... 10 mm²
 - others: solid wire 0.2 ... 4 mm²
 - stranded wire 0.2 ... 2.5 mm²

Permissible ambient conditions

- operating temperature -10°C...+55°C
- storage temperature -25°C...+55°C
- transport temperature -25°C...+70°C
- rel. humidity annual mean <75%
- for 30 days 95% at <40°C
- moisture condensation not permitted

Mechanical strength

- resistance to earthquakes (IEC 255-21-3)
 - nominal frequency range 1...35 Hz
 - cut-off frequency 8...9 Hz
 - horizontal 3.5 mm; 10 m/s²
 - vertical 1.5 mm; 5 m/s²
- vibration strain (IEC 255-21-1, IEC 68-2-6)
 - Fc: 10...150 Hz; 0.075 mm; 1g
- repeated impact strain (IEC 255-21-2, 68-2-27+29)
 - Ea: 11 ms, 15 g; Eb: 16 ms, 10 g

Auxiliary power supply

- U_H depending on design 24-65.5 V DC
- or 60-137 V DC, 60-100 V AC
- or 110-320 V DC, 100-240 V AC
- operating range 0.8-1.1·U_H
- power consumption <10 W
- stored energy time in case of auxiliary power failure, based on nominal voltage
 - ≥ 50 ms
- battery for data backup in case of auxiliary power failure 3 V CR ½ AA lithium

Measuring input circuits

- nominal frequency 50 Hz
- current paths rated current I_n (different terminals) 1 A / 5 A
- load capability permanent, 1 s 5·I_n
- limiting dynamic value (10 ms) 100·I_n
- power consumption at I_n <0.25 VA

Binary signal inputs (optocoupler) ¹

- nominal input voltage (V_i) 24...220 V DC
- power consumption < 4·10⁻⁴ (V_i)² W
- logic low level <10 V

¹ On special-wish, differently from the default long-range input voltage optocoupler inputs can be dimensioned for a Low/High switching voltage of about 60 V.

Output relays

- trip relays (marked S1, S2)
 - switching voltage 300 V DC, 250 V AC
 - limiting making capacity 2000 W (VA)
 - limiting breaking capacity
 - 90...250 W (voltage- and load dependent)
 - 0.25 A at 220 V DC, L/R = 0 ms
 - 0.15 A at 220 V DC, L/R = 40 ms
 - both contacts in series:
 - 0.25 A at 220 V DC, L/R = 40 ms
 - limiting continuous current 8 A
 - limiting short-time current for 0.5 s 30 A
- Exception:* S1 in Pl.-No. 1743 0xx xx0
 - switching voltage 250 V DC, AC
 - limiting making capacity 1250 W (VA)
 - limiting breaking capacity
 - 50...250 W (voltage and load dependent)
 - limiting continuous current
 - 1x8 A or 2x5 A /40°C
- signal relays (marked M1... M5)
 - switching voltage 300 V DC, 250 V AC
 - switching current 8 A
 - switching capacity <2000 VA,
 - 50...220 W (voltage-dependent)
 - limiting continuous current 6 A

Serial interface

- PC interface RS 232; 9-pin Sub-D
- optional: electrical isolation 1.5 kV
- IEC 60870-5-103 interface optional
- optical fibre connector F-SMA
- optical wavelength 850 nm
- distance < 1 km
- permissible path attenuation < 8 dB
- glass fibre 62.5/125 µm
- idle position light on
- or RS 485 half-duplex
- unit load 1
- potential separation 1.6 kV, 1 s
- connection terminal

Displays

- LED's green: 1; red: 1; yellow: 10
- LCD four-line of 20 characters each illuminated

Setting values and ranges (selection)

- characteristic sets 2
- line-fault overcurrent stages I_L
 - I_L>, definite-time 0.20...25·I_n
 - I_L>, inverse-time 0.20...4·I_n
 - I_L>>, definite-time 0.4...30·I_n
 - I_L>>>, definite-time 2 ...30·I_n
- earth-fault current stage
 - I_E>, definite-time 0.05...12·I_n
 - or sensitive version 0.01...2.5·I_n
 - I_E>, inverse-time 0.05...4·I_n
 - I_E>>, definite-time 0.05...15·I_n
 - or sensitive version 0.01...2.5·I_n
 - I_E>>>, definite-time 0.1...15·I_n
 - or sensitive version 0.01...2.5·I_n
- resetting ratios 0.20...0.95
- definite-time time stages
 - t_{i>>>} 0...65 s
 - 0...9.99 s
- inverse-time time stages
 - time factor t_>, t_E 0.05...2 s
 - release time, maximum t_{a_max} 10...60 s
- Switch-on protection I_L>SOP 0.40...28·I_n
- I_E>SOP 0.05...15·I_n



or sensitive version	0.01...2.5·In
- inrush restraint up to IL	2.00...25·In
I ₁₀₀ /I ₅₀ >	0.10...0.45
max time for crossblocking	0.00...60 s
- thermal replica (overload protection)	
basic current I _B	0.2...2·In
operate factor k	1.00...1.20
thermal time constant	1...960 min
warning levels	40...98%
- auto-recloser	
short dead time	0.05...9.99 s
long dead time	1...300 s
action time window	0.05...9.99 s
reclaim and blocking time	1...300 s
- I _{min} CBF	0.1...1.99·In
t _{CBFi} , t _{CBFe}	0.1...1.99 s

Routine testing

- dielectric test	2.5 kV, 50 Hz, 1 s
exception: power supply	2.83 kV DC
RS485	1.6 kV, 1 s
- Each protection relay will be subjected to a 72-hour alternate temperature test while in function.	

Type testing

- impulse voltage test	5 kV; 1.2/50 µs; 500 Ω
- dielectric test	2.5 kV, 50 Hz, 60 s
exception: power supply	2.83 kV DC
RS485	1.5 kV, 60 s
Isolated PC interface	1.5 kV, 60 s
- EMC noise immunity	EN 50082-2, severity class 3
electromagnetic RF field	
magnetic field of power engineering frequency	
discharge of static electricity (ESD)	
fast transients (bursts)	
transients (surges)	
RF interference test (IEC 255-22-1)	
transformer cross voltage	2.5 kV
- EMC emitted interference	EN 50081-2 -B

Order data DSZ 2

PI.-No.: 1743	0	↑	↑	↑
current transformer: 6 th digit				
I _E > from 0.05·In	0			
I _E > from 0.01·In	2			
auxiliary voltage: 7 th digit ²				
110 - 240 V DC/AC	0			
60 - 137 V DC	1			
24 - 65 V DC	2			
type of housing: 8 th digit				
panel surface-mounted				
CT terminals down		0		
CT terminals right		2		
CT terminals left		4		
panel flush-mounted				
CT terminals down		1		
CT terminals right		3		
CT terminals left		5		
IEC interface / language: 9 th digit				
Fibre optical / German		0		
Fibre optical / English		1		
RS485 / German		5		
RS485 / English		6		
design: 10 th digit				
		0		
		1		
		3		

Design includes:	0	1	3
Binary inputs	2	5	5
Trip relays	1	2	2
Pilot relays (1 CO contact)	2	2	2
Pilot relays (1 make contact)	0	3	3
PC interface electrically isolated	X	X	X
IEC 60870-5-103 interface	-	X	-
Auto reclosing	-	X	X
Inrush restraint	X	X	X
Pulse shaper stage	X	X	X

Optocoupler inputs:

On special-wish, differently from the default long-range input voltage optocoupler inputs can be delivered with a Low/High switching voltage of about 60 V. This wish is separated with order to declare.

² complete voltage ranges see Technical Specifications

Accessories

PC-protector interconnecting cable
PI. No.: 1743 900 010

COMM-3 PC operator software• **Management program**

PI.-No.: 1744 990 00 -
Variant: 10th digit ↑
 Full-version 0
 Upgrade from COMM-2 to 3 1
 Update of COMM-3 2
 Demo version 9
On supplied CDROM the user manual exists as a PDF-file.

• **Device programs**

PI.-No.: 1744 991 - - ↑ ↑ ↑
Type of device: 8th and 9th digit ↑ ↑ ↑
 all devices [structure versions] 0 0
 DM 2 [1004] 1 0
 DSRZ(W) 2 [2001] 2 0
 DSZ(W) 2 [3007] 3 0
 DSZW 4 [3105] 3 1
 DSZ 4 [3205] 3 2
 DQ2S 2, DQ3S 2 [4008] 4 0
 DD 2 [5033] 5 0
 P9x-DD.. 6 [5601] 5 6
 DDS(E) 2 [6002] 6 0
 DSRZE 2 [7000] 7 0
 P9x-DS.. 6 [7604] 7 6
Variant: 10th digit ↑
 current structure version 0
 old structure version 1

When reordering a device program the structure version number of the device is necessary additionally (see label on device). Example for DSZ 2, old structure version 3001:

PI.-No. 1744 991 **301- 3001**

SDA 2 graphics software

PI.-No.: 1744 992 000
On supplied CDROM the user manual exists as a PDF-file.

User manuals COMM-3, SDA 2 printed version

PI.-No.: 1744 993 0 - - ↑ ↑ ↑
Language: 9th digit ↑
 German 0
 English 1
Manual: 10th digit ↑
 COMM-3 0
 SDA 2 1

Sprecher Automation
Deutschland GmbH
Moellendorffstr. 47
10367 Berlin
Germany
Tel: +49 30 6449241-70
Fax: +49 30 6449241-99
Email: info@sprecher-automation.com
Internet: www.sprecher-automation.de, www.sprecher-automation.at, www.sprecher-automation.com, www.sprecher-automation.pl, www.sprecher-automation.sk

Sprecher Automation GmbH
Frankstrasse 51
4018 Linz
Austria
Tel: +43 732 6908-0
Fax: +43 732 6908-321

Sprecher Automation GmbH
Ignaz-Koeck-Straße 10
1210 Wien
Austria
Tel: +43 732 6908-601
Fax: +43 732 6908-5601

Sprecher Automation
Polska Sp z o.o.
ul. Łączna 4
58-100 Świdnica
Poland
Tel: +48 74 85135-31
Fax: +48 74 85135-32

Sprecher Automation
spol. s r.o.
Kopčianska 14
851-01 Bratislava
Slovakia
Tel: +421 2 682055-00
Fax: +421 2 682055-10

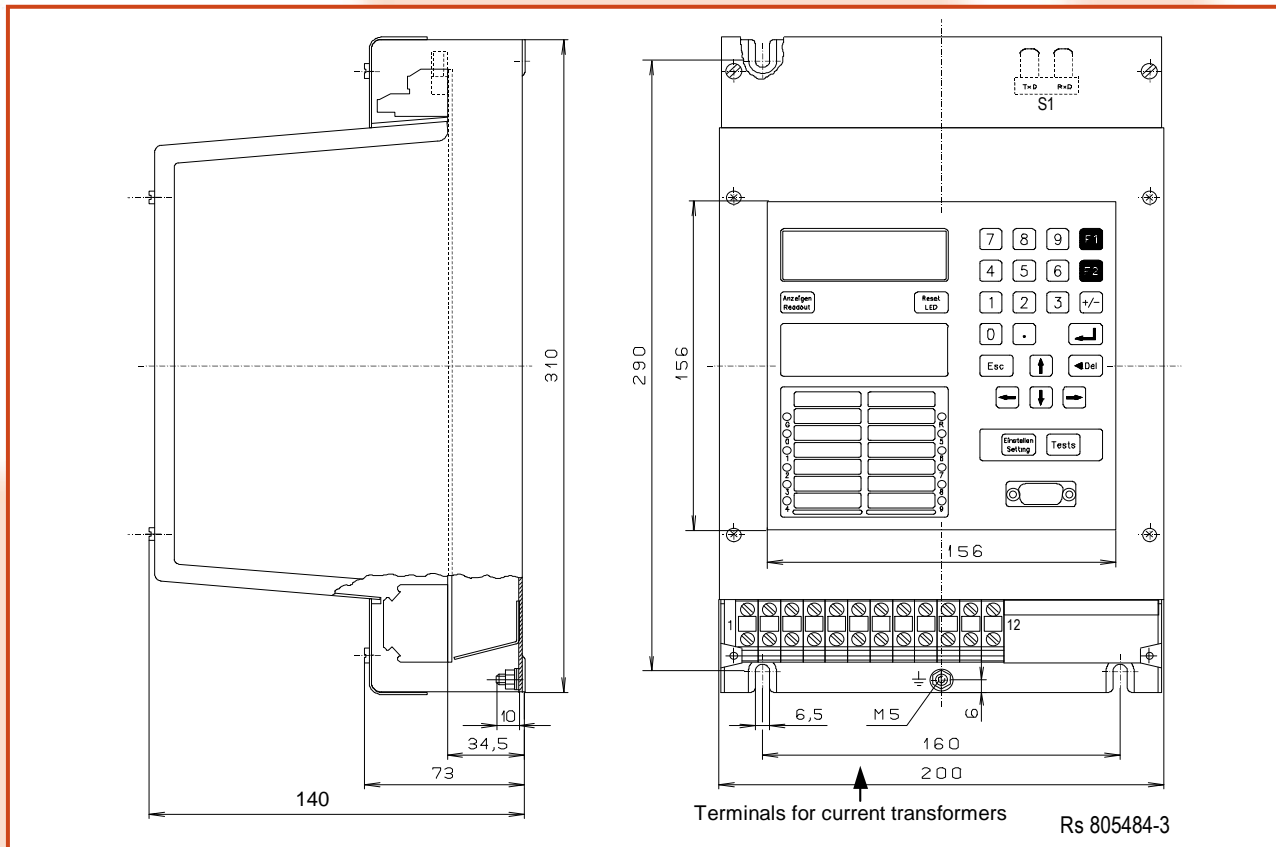

Fig. 7: DSZ 2 housing for panel surface mounting, lower terminal cover not shown in top view. With the horizontal models the keypad is turned + or -90°.

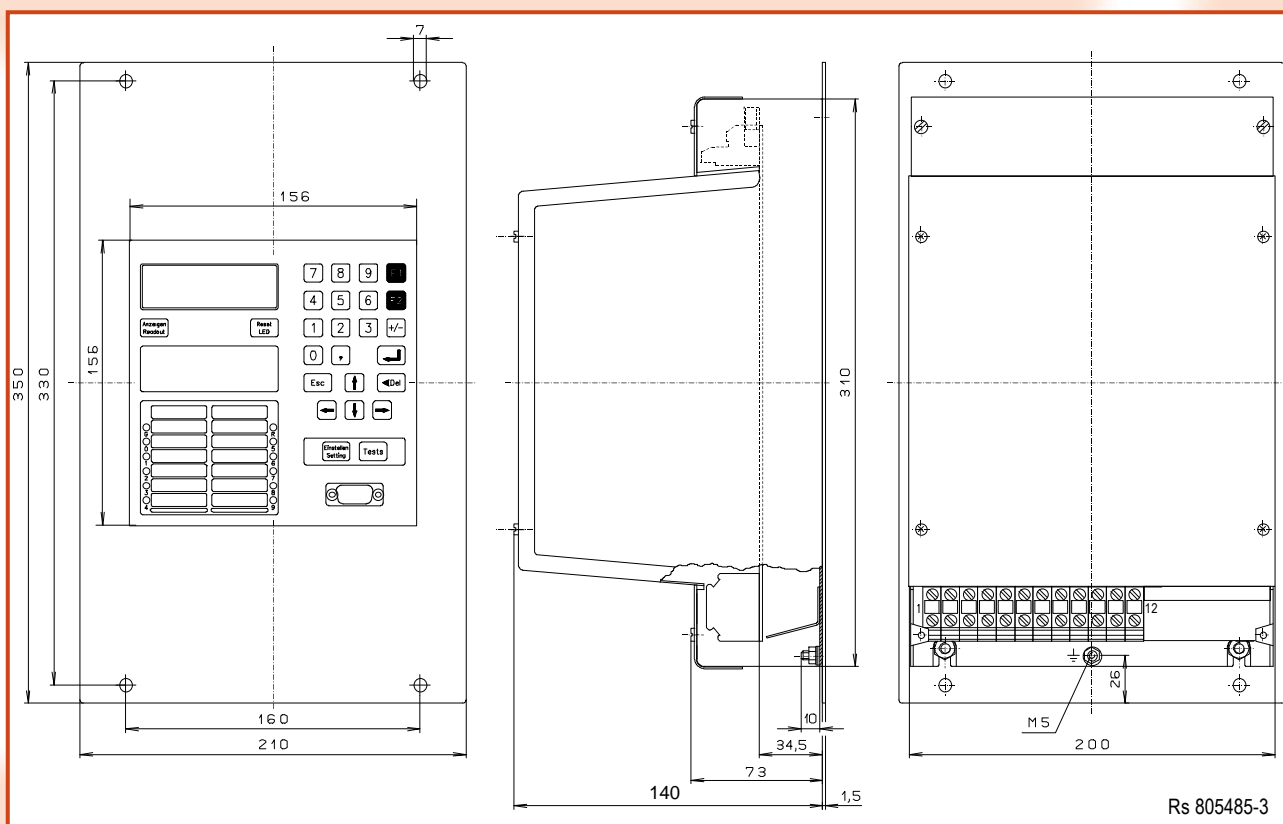

Fig. 8: DSZ 2 housing for panel flush mounting, lower terminal cover not shown in rear view (right-hand side). The panel cut-out should be 202 mm x 312 mm when device will be put through from front side. With the horizontal models the keypad is turned + or -90°.

